

Squishy Blob

By Jeremy Shafer ©1999

What's that? It's a pointy thingamajing that bounces up and down like a trampoline. Its primary use is as a finger exercising device. However, it can also be used to distract professors while they are trying to lecture.

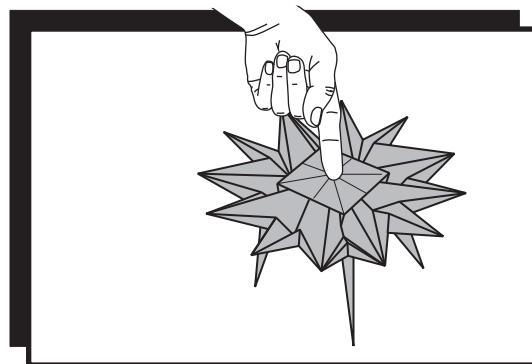

1

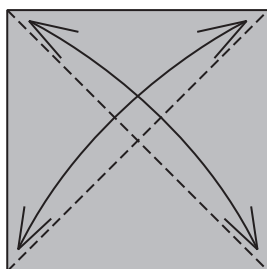

Works best folded from 6" paper. Valley-fold and unfold diagonally in half. Turn over.

2

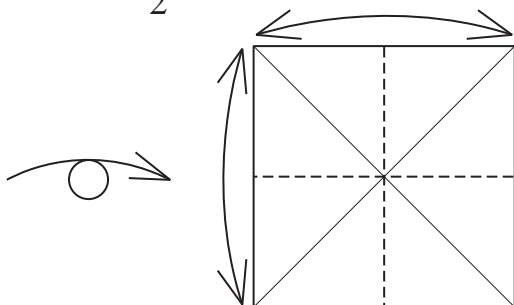

Valley-fold and unfold in half.

3

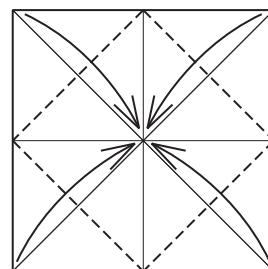

Blintz!

4

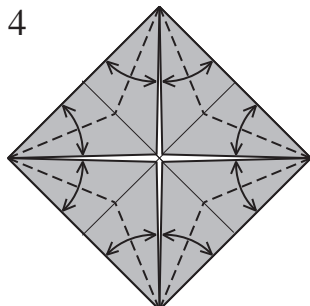

Valley-fold and unfold.

5

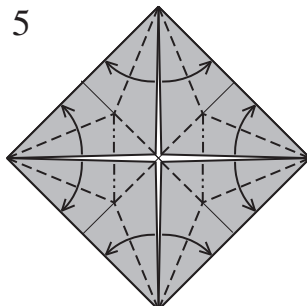

Along existing creases, make rabbit ears out of the corners.

6

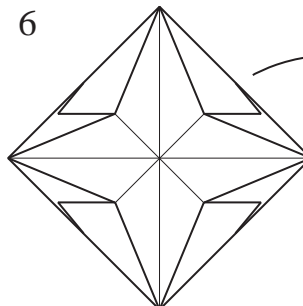

Like this. Turn over.

7

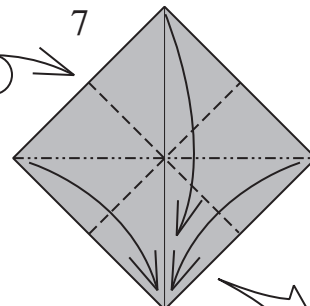

Fold a preliminary base.

8

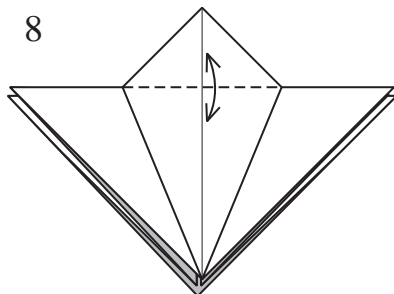

Valley-fold and unfold.

9

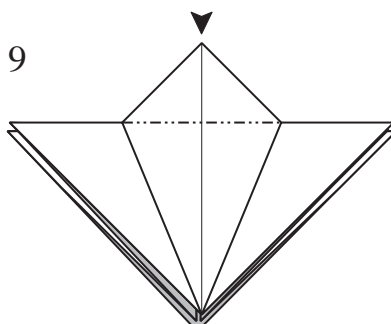

Sink!

10

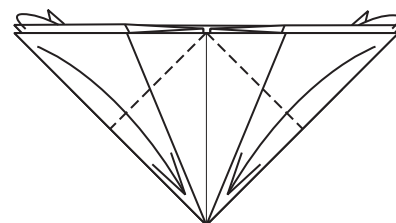

Valley-fold. Repeat behind.

11

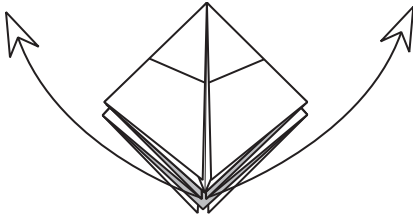

Pull out the inner-most corners.

12

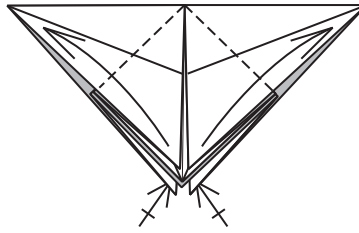

Valley-fold the corners back up. Repeat behind.

13

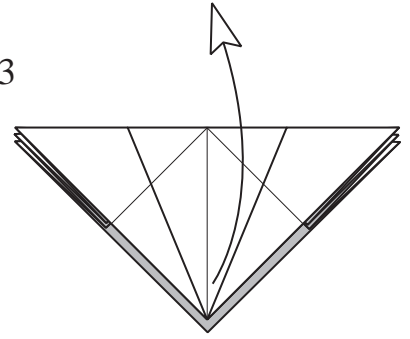

Swing up the front layers. Flatten the model by spread-squashing the center thus forming a square.

14

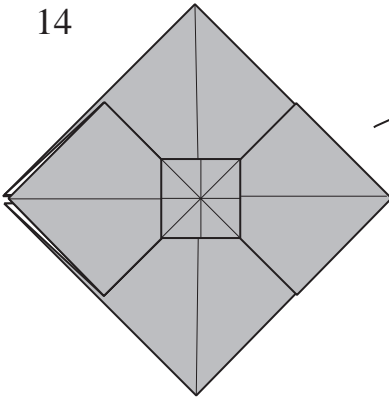

Like this. Turn the model over.

15

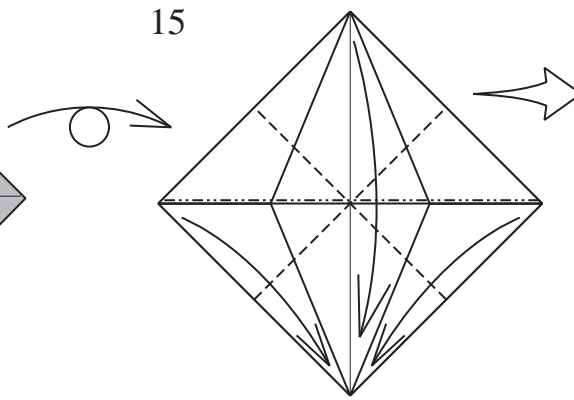

Fold a preliminary base.

16

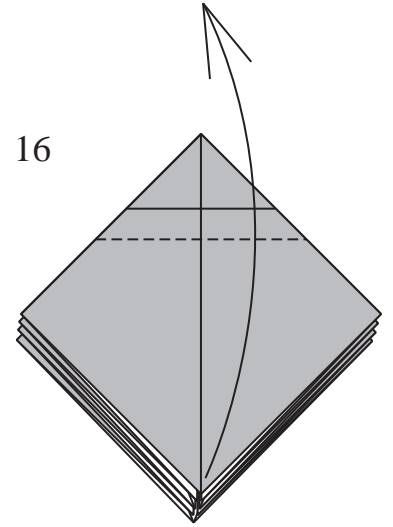

Lift up the front flap up as if to make a petal fold, but don't flatten.

17

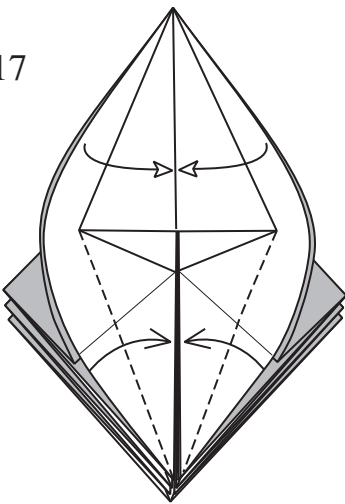

Erase all the white.

18

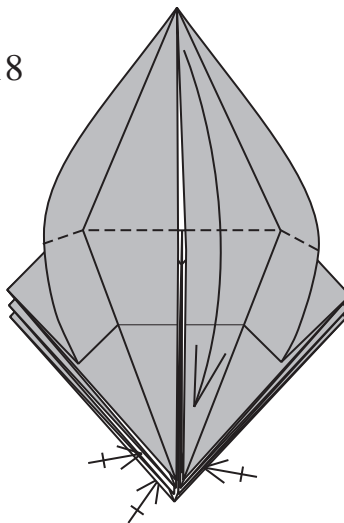

Fold the flap back down. Repeat steps 16-18 on the other three such flaps.

19

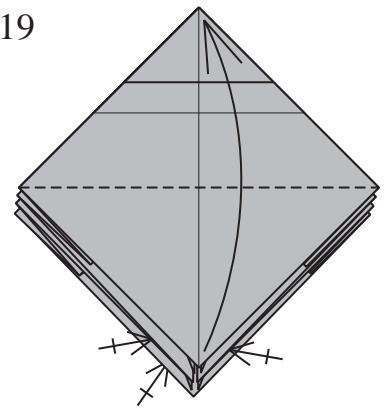

Valley-fold the front flap. Repeat on the other three such flaps.

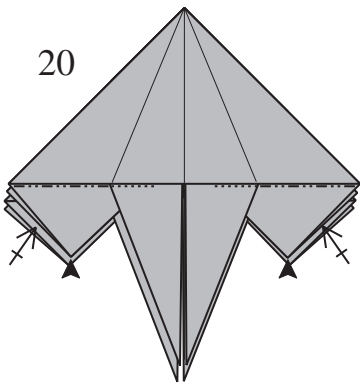

20

Reverse-fold.

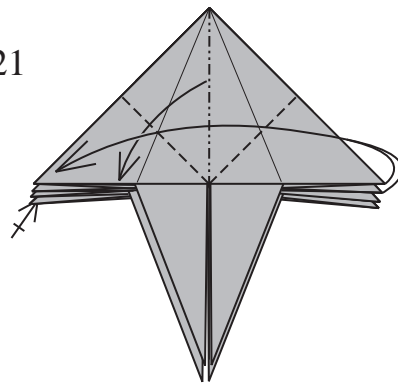

21

Swing the two front right corners to the left incorporating a reverse fold. Balance the model out by repeating behind.

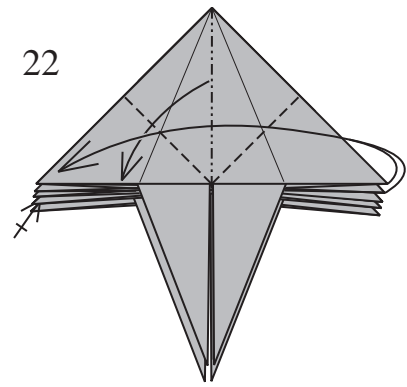

22

Repeat step 21 with the next set of flaps. The first set of step 21 reverse folds will come undone. Repeat behind.

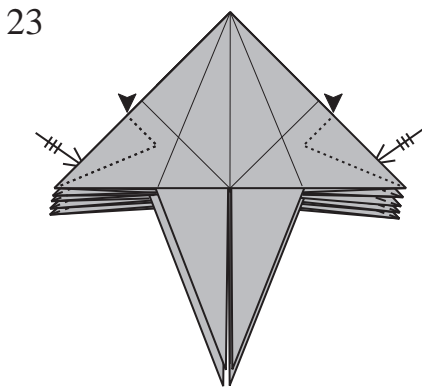

23

Make eight lovely little reverse folds.

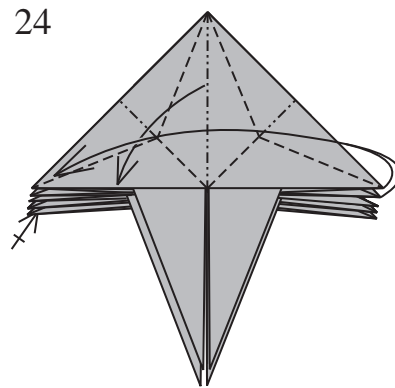

24

Repeat step 21 again, this time incorporating the four remaining lovely reverse folds. Upon performing this fold, the model will be all done.

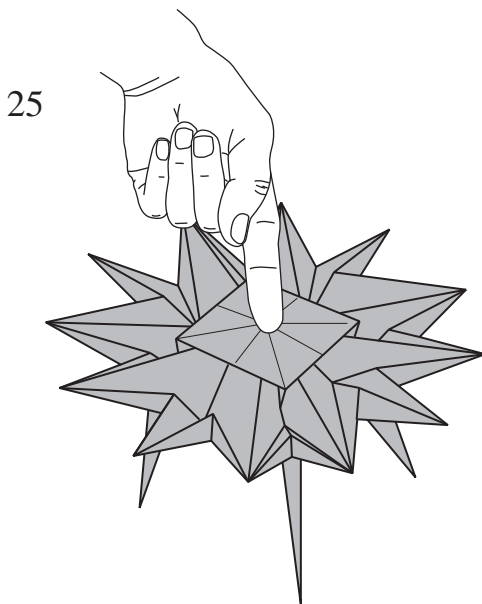

25

The trampoline is well done. Shrink yourself to the weight of a pencil and bounce bounce bounce, or more simply, bounce on it with your finger as shown.

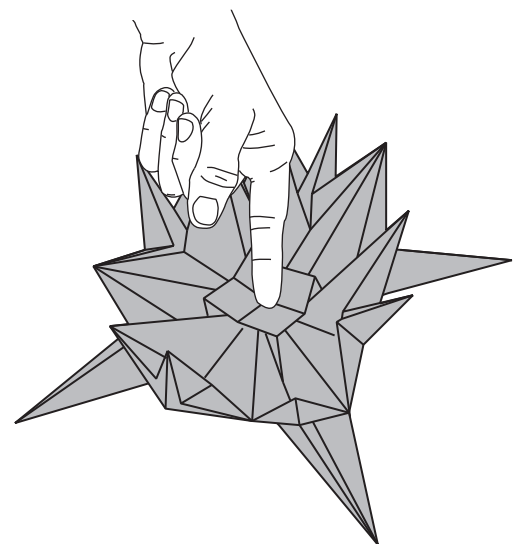

26

The trampoline has been jumped on. Pull your finger away and the model will spring back up.